

Pokretanje elektromotora u spoju zvijezda-trokut s reverziranjem

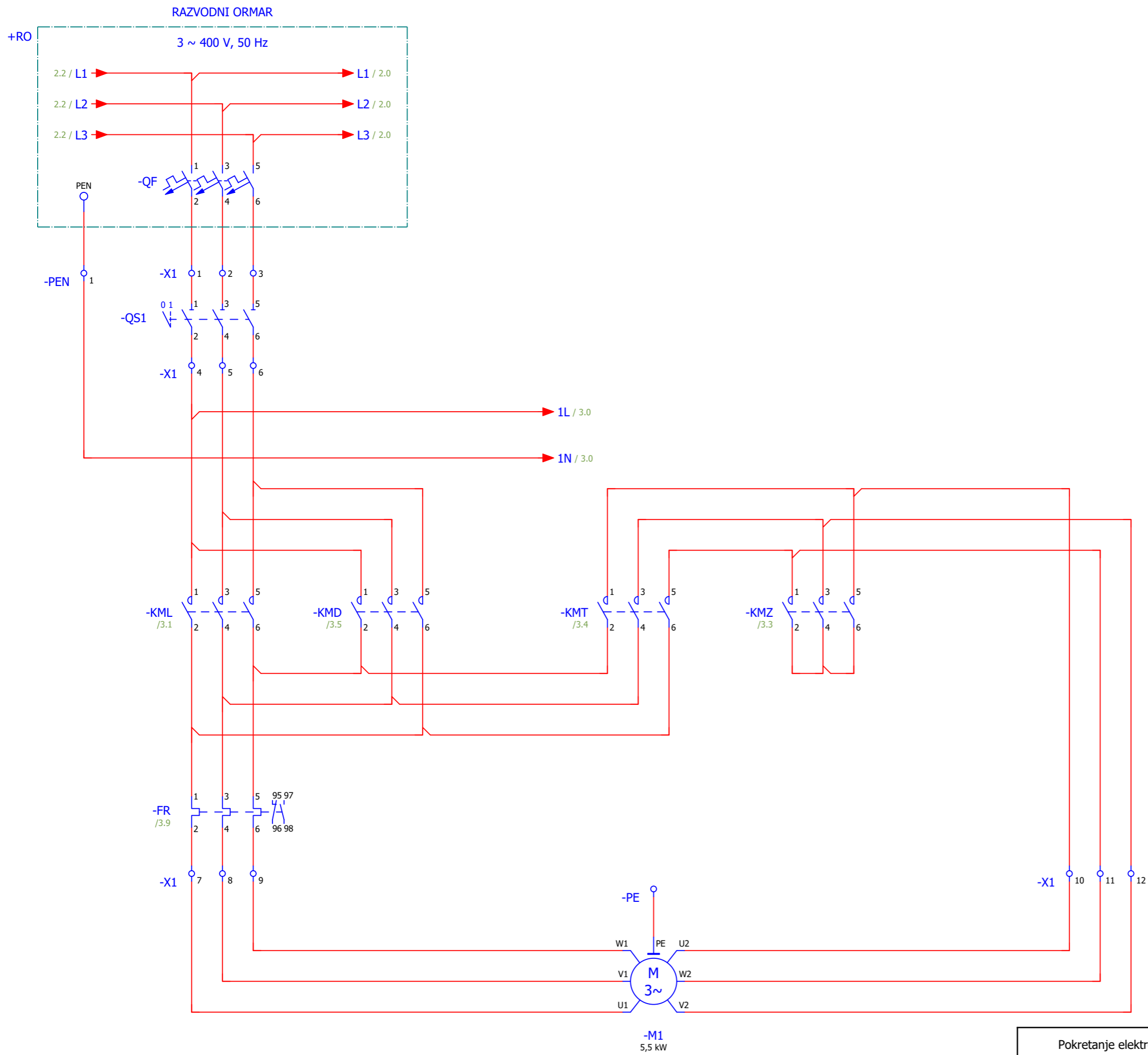

Pokretanje elektromotora u spoju zvijezda-trokut s reverzirajnem	Datum	2/1/2026
Energetska shema	Stranica	2/5

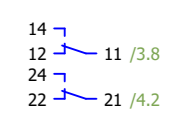
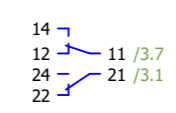
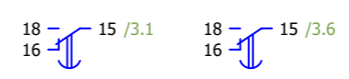
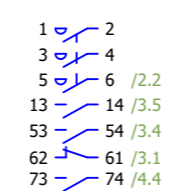
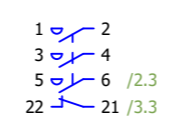
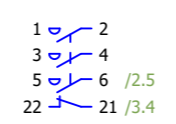
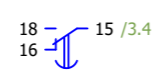
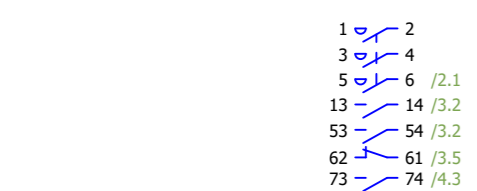
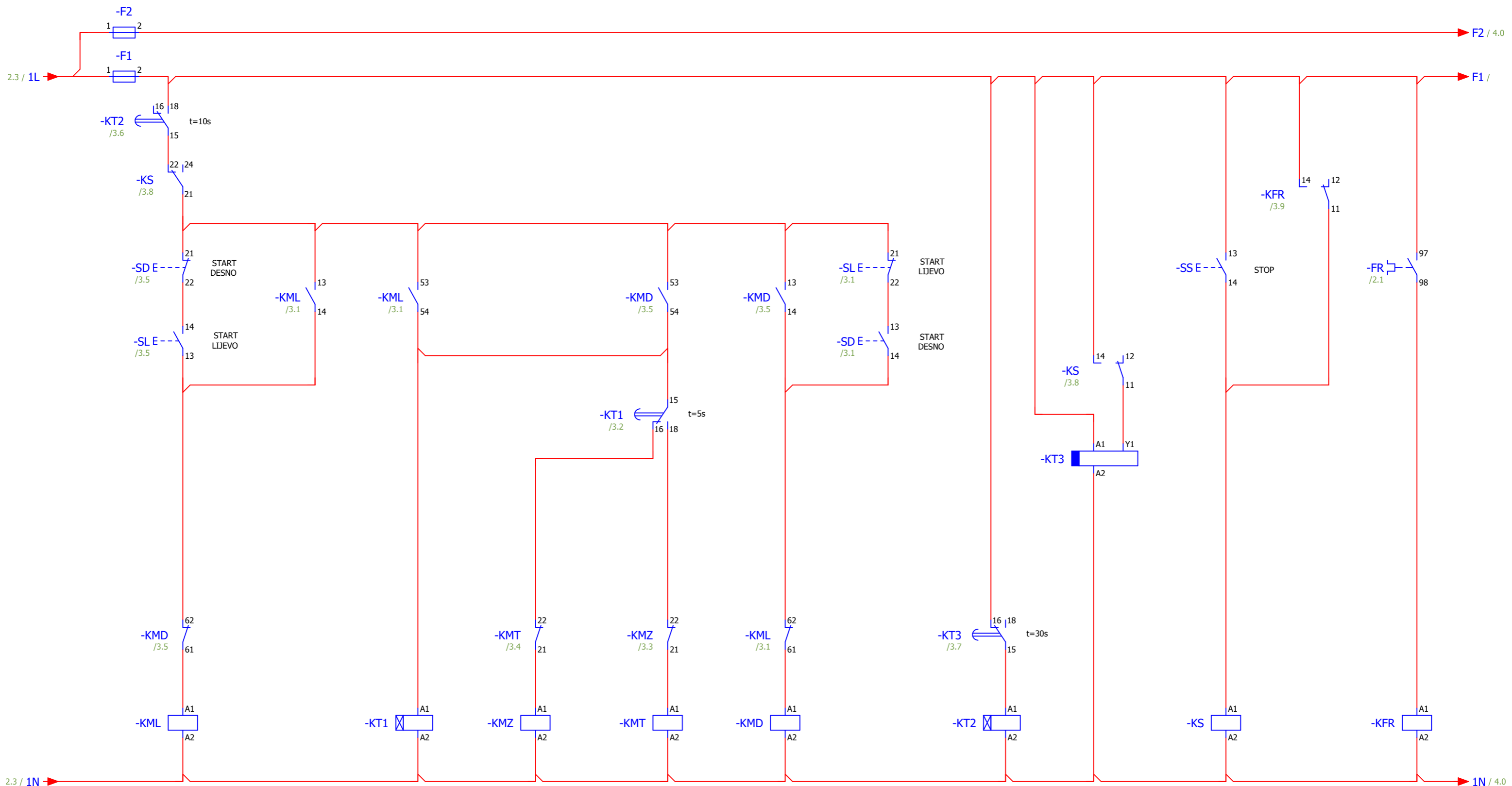

Pokretanje elektromotora u spoju zvijezda-trokut s reverzirajnem	Datum	2/1/2026
Schema upravljanja	Stranica	3/5

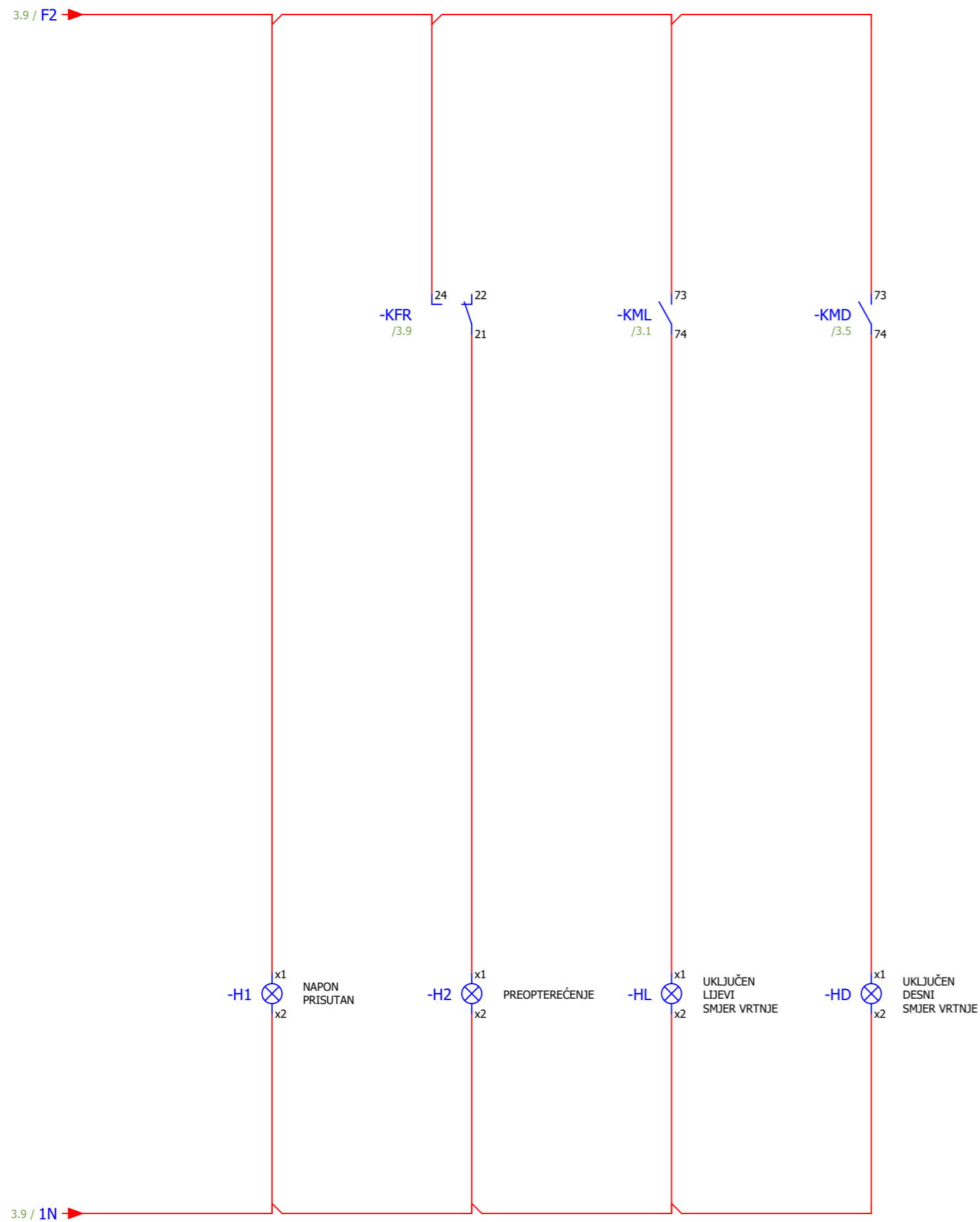

Legenda

Simbol	Značenje
-F1	Osigurač upravljačkog kruga
-F2	Osigurač upravljačkog kruga
-FR	Termički relej
-H1	Lampica NAPON PRISUTAN
-H2	Lampica PREOPTEREĆENJE
-HD	Lampica DESNI SMJER VRTNJE UKLJUČEN
-HL	Lampica LIJEVI SMJER VRTNJE UKLJUČEN
-KFR	Relej upravljanja
-KMD	Sklopnik desnog smjera vrtnje
-KML	Sklopnik lijevog smjera vrtnje
-KMT	Sklopnik spoj trokut
-KMZ	Sklopnik spoj zvijezda
-KS	Relej upravljanja
-KT1	Vremenski relej s kašnjenjem uklopa
-KT2	Vremenski relej s kašnjenjem uklopa
-KT3	Vremenski relej s kašnjenjem uklopa
-M1	Elektromotor 400 V 5,5 kW
-QS1	Grebenasta sklopka
-SD	Tipkalo START DESNO
-SL	Tipkalo START LIJEVO
-SS	Tipkalo STOP
-QF	Tropolni minijturni prekidač